

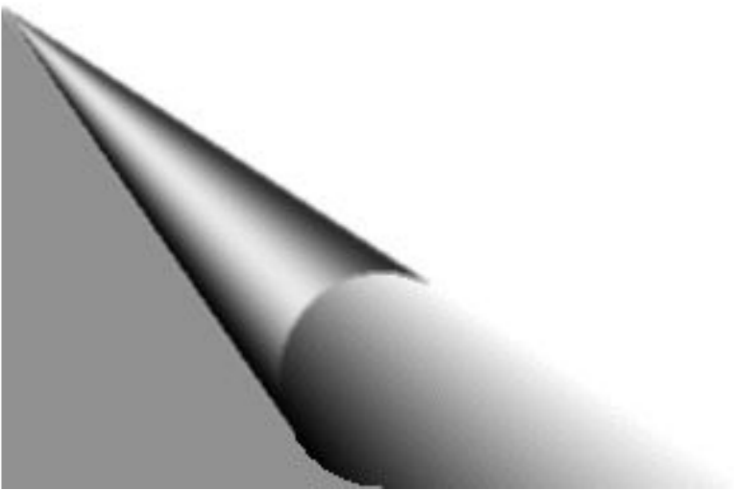

TEN PLUS ARCHITECTURAL

Louvers • Sunshades • Vision Screens



OUR COMMITMENT

TEN Plus owes its success to the simple business philosophy of providing quality products, great service, and an unwavering commitment to customer satisfaction.

We accomplish our goals by investing in people and technology. We strive to improve productivity and optimize the use of our resources through investment in state-of-the-art equipment, training and the use of innovative design principles. Rigorous quality control and workplace safety practices ensure the well-being of our employees and business partners.

Our technical representatives possess comprehensive louver knowledge and extensive field experience. Each one is capable of assisting you through the design and engineering stage, as well as overcoming the unforeseen field conditions.

We trust that this catalogue will prove to be a useful aid and resource to selecting your louvers, sunshades and vision screens. However, should you have any questions or unique conditions requiring greater detail, please feel free to call us for assistance. Our staff is attentive to your needs and eager to serve you. We look forward to your call.

TABLE OF CONTENTS

TABLE OF CONTENTS	02	MODEL V4454 SIGHT PROOF LOUVER	20
LOUVER SELECTION CHART	03	MODEL H2451 STORM BLADE LOUVER	22
LOUVER SELECTION GUIDELINES	04	MODEL P4451 LOUVERED PENTHOUSE	24
ACCESSORIES	05	ACOUSTICAL LOUVERS	25
FINISHES	05	MODEL S4522 LOUVERED VISION SCREEN	26
MODEL R7355 STORM RESISTANT LOUVER	06	MODEL S4454 LOUVERED VISION SCREEN	27
MODEL R5455 STORM RESISTANT LOUVER	08	MODEL T1300 THINLINE LOUVER	28
MODEL D6403 DRAINABLE LOUVER	10	MODEL G1384 DOOR GRILLE	28
MODEL D4493 DRAINABLE LOUVER	12	MODEL B4450 BLOCK VENT	29
MODEL H6451 STORM BLADE LOUVER	14	SOLAR CONTROL	30
MODEL H4451 STORM BLADE LOUVER	16	SUNSHADE COMPONENTS	31
MODEL S6452 STRAIGHT BLADE LOUVER	18		

NOTE: Although great care has been taken in the production of this catalogue, illustrative or copy errors may occur. TEN Plus Architectural Products Ltd. assumes no liability for any errors contained herein. This publication supercedes all prior technical, policy, and print data. Specifications subject to change without notice.

Copyright © 2013 TEN Plus Architectural Products Ltd. ALL RIGHTS RESERVED. Printed in Canada

LOUVER SELECTION CHART

EXTRUDED ALUMINUM LOUVERS + VISION SCREENS

Model	Classification	Depth	Min. Height	AMCA Air Performance Certification	AMCA Water Performance Certification	AMCA Wind Driven Rain Certification
G1384	Door grille	1-3/8" - 1-3/4" (35 - 45mm)	6" (152mm)	-	-	-
B4450	Block vent	4" (102mm)	4" (102mm)	-	-	-
H2451	Storm blade	2" (52mm)	12" (305mm)	-	-	-
H4451	Storm blade	4" (102mm)	18" (457mm)	Yes	Yes	-
V4454	Sight proof	4" (102mm)	18" (457mm)	-	-	-
D4493	Drainable	4" (102mm)	18" (457mm)	Yes	Yes	-
H4451	Louvered Penthouse	4" (102mm)	18" (457mm)	Yes	Yes	-
S4522	Vision screen	4" (102mm)	18" (457mm)	-	-	-
V4454	Vision screen	4" (102mm)	18" (457mm)	-	-	-
R5455	Storm resistant	5" (127mm)	18" (457mm)	Yes	Yes	Yes
H6451	Storm blade	6" (152mm)	18" (457mm)	Yes	Yes	-
D6403	Drainable	6" (152mm)	18" (457mm)	Yes	Yes	-
S6452	Vision screen	6" (152mm)	18" (457mm)	-	-	-
A6457	Acoustical	6" (152mm)	18" (457mm)	-	-	-
R7355	Storm resistant	7" (178mm)	18" (457mm)	Yes	Yes	Yes
A8457	Acoustical	8" (203mm)	18" (457mm)	-	-	-
A12457	Acoustical	12" (305mm)	18" (457mm)	-	-	-

LOUVER SELECTION GUIDELINES

FREE AREA

Free area is the unobstructed area of a louver through which air can pass freely. The free area and total volume of air will determine the velocity of air through the louver. The free area velocity determines the size of the louver based on design constraints such as static pressure drop and water penetration.

SIZING LOUVERS

To choose the correct louver size, please use the following steps:

- Determine which louver would be best suited for the application.
- Determine the total volume of air (Cubic Feet per Minute or CFM) that will pass through the louver.
- Determine the most important design criteria, by choosing from a, b or c:
 - a) Not to allow water to penetrate the louver. If water penetration is the most important design criteria, then use a velocity less than that shown on the water penetration chart.
 - b) Not to exceed a determined static pressure drop. If static pressure drop is the most important design criteria, then use a velocity equal to that shown on the pressure drop chart.
 - c) If both are equally important, use the lower of the two velocities.
- To determine the total free area required, divide the volume of air (CFM) by the velocity through the free area (FPM).
- Match the free area required to the free area chart of the chosen louver. This will determine the overall dimensions of the louver required.

Feel free to call us for assistance on proper louver sizing.

DRAINABLE LOUVERS

Drainable louvers are designed to collect the water that flows down each individual blade face and disperse the water through spouts in the mullions and jamps.

Drainable louvers are effective only when the blades and drainage spouts are free of debris. They should be checked regularly and cleaned when necessary, to ensure they continue to perform well. To benefit from their performance, drainable louvers should never be specified as continuous line louvers. The design of the louver system requires that the collected water be diverted from the face of each blade. By eliminating the visible mullions on a large span of drainable louvers, it is possible for water to collect in the gutters and overflow. This overflow, cascades down the face of the louver and may be sucked into the fans and mechanical systems behind the louver.

ACCESSORIES

AVAILABLE ACCESSORIES

- Custom louver shapes available
- Flanged frames
- Frames with glazing adaptor for curtain wall and window mullions
- 1/2" x 1/2" (12 x 12mm) inter-crimped 14 gauge (0.063") aluminum bird screens
- 5/8" (16 mm) mesh, 0.50" (1.27 mm) thick expanded and flattened aluminum bird screen
- 16 x 18 aluminum mesh insect screen
- Continuous blade construction with hidden mullions to give an uninterrupted appearance
- Continuous blade construction is not recommended for use on drainable louvers, save for model R7355
- Single sheet and insulated blank-off panels are available in aluminum or galvanized steel
- All welded construction is available when required
- Hinged louvered doors for applications that require access to the room or equipment behind the louver
- Security bars behind louvers
- Custom sill lengths and shapes are available

If you require an item not shown here, please contact our office. We will assist you in designing a louver or a feature that meets your design requirements.

FINISHES

• THREE COAT SYSTEM

Superior performance three coat system (primer/colour coat/clear coat) including thermal setting application of 70% fluoropolymer resin minimum, PVDF with added colour pigment finish exceeding or meeting AAMA 2605 requirements. Ensure fluoropolymer baked resins form a continuous physically locked finish during manufacturing process. Apply fluoropolymer finish after multistage chemical treatment cleaning providing corrosion resistance surface ready to receive primer. Acceptable Product: Duranar XL by PPG Industries or equivalent by Valspar.

• TWO COAT SYSTEM

High performance two coat system including thermal setting application of 70% fluoropolymer resin minimum, PVDF with added colour pigment finish exceeding or meeting AAMA 2605 requirements. Ensure fluoropolymer baked resins form a continuous physically locked finish during manufacturing process. Apply fluoropolymer finish after multistage chemical treatment cleaning providing corrosion resistance surface ready to receive primer. Acceptable Product: "Duranar" by PPG Industries or equivalent by Valspar.

• ONE COAT SYSTEM

Pigmented Organic Thermal Setting Finish Process: (1 Coat Wet System) meeting or exceeding AAMA 2603. Acceptable Product: "Duracron" by PPG Industries or equivalent by Valspar.

• COLOUR ANODIZED FINISH

Ensure aluminum finish is colour anodized in accordance with Aluminum Association Finish Designation AA-M12C22A44, Class I, minimum 0.018 mm (0.7 mils) thick finish. Colour to be selected by consultant.

• CLEAR ANODIZED FINISH

Ensure aluminum finish is clear anodized in accordance with Aluminum Association Finish Designation AA-M12C22A41, Class I, minimum 0.018 mm (0.7 mils) thick for exterior applications and AA-12C22A31, Class II, minimum 0.01 mm (0.4 mils) thick for interior applications.

MODEL R7355 STORM RESISTANT DRAINABLE LOUVER

PERFORMANCE

Performance Rating Standard	AMCA Standard 500L
Louver Type	Continuous Line or Mullion Construction
Louver Depth	7" (178 mm)
Blade Angle	35°
Free Area – 4'x4' Unit	8.03 sq.ft. (0.75 m ²)
Percentage Free Area	50.3%
Free Area Velocity at Beginning Point of Water Penetration (0.01 oz / ft ²)	759 FPM (3.86 m/s)
Air Volume at Beginning Point of Water Penetration 4' x 4' Unit (test duration of 15 minutes)	6097 CFM (2.9 m ³ /s)
Pressure Drop at Beginning Point of Water Penetration	0.25 in. H ₂ O (62.3 Pa)
Notes	Tested without bird screens
WIND DRIVEN RAIN WATER PENETRATION DATA (29 mph (13 m/s) wind velocity with a 3 in/hr (75 mm/hr) rainfall rate):	
Effectiveness Ratio: 99.1% (Class "A" Rating)	Core Ventilation Rate: 1.0 m/s (196 fpm) Free Area Velocity: 1.7 m/s (342 fpm)
Effectiveness Ratio: 98.7% (Class "B" Rating)	Core Ventilation Rate: 1.4 m/s (280 fpm) Free Area Velocity: 2.5 m/s (490 fpm)

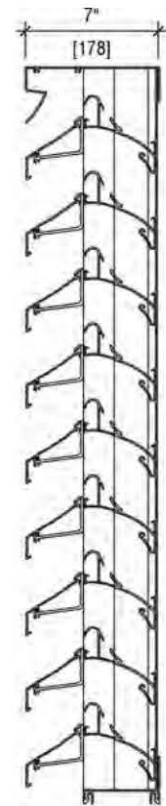

VERTICAL SECTION

ABBREVIATED SPECIFICATION

Where indicated on drawings, supply and install 7" (178 mm) deep, storm resistant louver Model R7355. Submit all details to consultant for approval prior to fabrication.

Head, sill, jambs, mullions, and blades shall have a nominal thickness of 0.080" (2.0 mm) 6063-T5 aluminum alloy. Jambs and Mullions to be recessed and concealed, and shall have integral vertical gutters to direct water to the bottom of the exterior face of the louver away from the building. Front blades shall be continuous, with no exposed vertical mullions, with rear blades that include an integral horizontal gutter to lead water to the vertical gutters in the mullions and jambs. Provide a sill pan flashing at base of louvers. Louvers shall be supplied with a 1/2" (12 mm), 19 gauge (1 mm) welded and re-galvanized wire mesh in a mill finish, with aluminum frame. Fasteners shall be standard zinc plated steel or stainless steel.

Materials Manufacturer: Ten Plus Architectural Products Ltd., 26 - 6535 Millcreek Drive, Mississauga, Ontario, Canada, L5N 2M2; Phone: (866) 884-0717; Email: info@tenplus-online.com; URL: www.tenplus-online.com

Structural supports shall be designed and furnished by the louver manufacturer to support a wind load of 20 psf (958 Pa), unless specified otherwise. Any louver opening greater than 10' (3 m) high, will require a horizontal girt at mid span, by others.

The louver manufacturer shall submit data, on a 4' x 4' (1.2 x 1.2 m) unit, showing that the louver performs to the above criteria, based on tests & procedures performed in accordance with the AMCA Publication 511, and comply with the "Certified Ratings Program" licensed to bear the AMCA seal.

Louvers shall be fabricated with mill finish aluminum and the finish shall be applied after assembly. Select desired finish from the following:

For superior performance, 3 coat PVDF system including a thermal setting application of 70% fluoropolymer resin. OR High performance 2 coat, PVDF system including a thermal setting application of 70% fluoropolymer resin. OR Pigmented Organic Thermal Setting Finish 1 coat system meeting or exceeding AAMA 2603. OR (Color Anodize) Ensure aluminum finish is colour anodized in accordance with Aluminum Association Finish Designation AA-M12C22A44, Class I, minimum 0.018 mm (0.7 mils) thick finish. Color to be selected by consultant. OR (Clear Anodize) Ensure aluminum finish is clear anodized in accordance with Aluminum Association Finish Designation AA-M12C22A41, Class I, minimum 0.018 mm (0.7 mils) thick for exterior applications and AA-12C22A31, Class II, minimum 0.01 mm (0.4 mils) thick for interior applications.



FLANGE FRAME
OPTIONAL

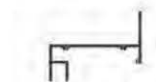

GLAZING FRAME
OPTIONAL



PERFORMANCE RATINGS – LOUVER MODEL R7355

FREE AREA CHART

		Louver Width				
		12	24	36	48	60
inches						
mm		305	610	914	1219	1524
Free Area - Square Feet / Square Meters						
12		0.30	0.69	1.07	1.46	1.84
305		0.03	0.06	0.10	0.14	0.17
24		0.76	1.72	2.69	3.65	4.61
610		0.07	0.16	0.25	0.34	0.43
36		1.22	2.76	4.30	5.84	7.38
914		0.11	0.26	0.40	0.54	0.69
48		1.68	3.79	5.91	8.03	10.15
1219		0.16	0.35	0.55	0.75	0.94
60		2.13	4.83	7.52	10.22	12.91
1524		0.20	0.45	0.70	0.95	1.20
72		2.59	5.86	9.14	12.41	15.68
1829		0.24	0.54	0.85	1.15	1.46
84		3.05	6.90	10.75	14.60	18.45
2134		0.28	0.64	1.00	1.36	1.71
96		3.51	7.93	12.36	16.79	21.22
2438		0.33	0.74	1.15	1.56	1.97
108		3.96	8.97	13.97	18.98	23.98
2743		0.37	0.83	1.30	1.76	2.23
120		4.42	10.00	15.58	21.17	26.75
3048		0.41	0.93	1.45	1.97	2.49
132		4.88	11.04	17.20	23.36	29.52
3353		0.45	1.03	1.60	2.17	2.74
144		5.33	12.07	18.81	25.55	32.28
3658		0.50	1.12	1.75	2.37	3.00

AIR FLOW RESISTANCE (TEST SIZE OF 4' X 4')

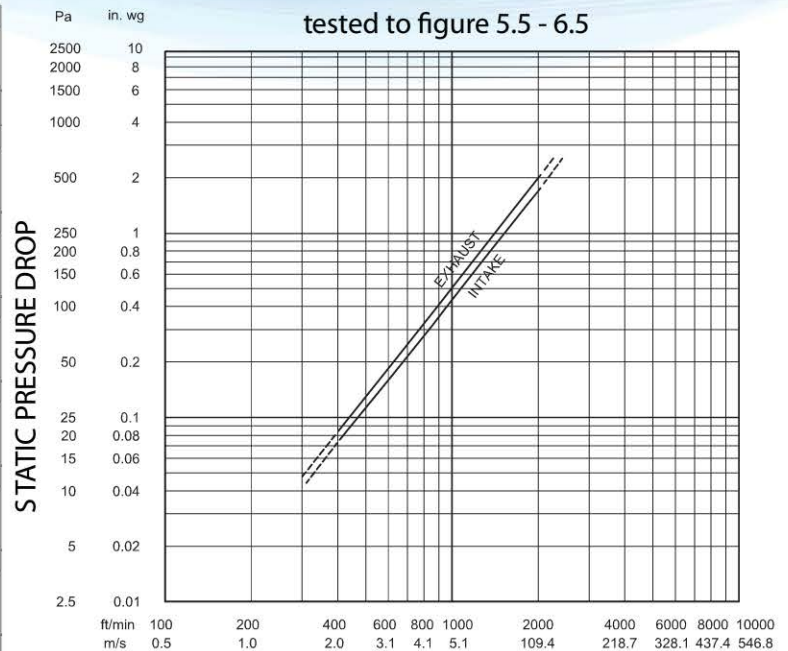

AIR VELOCITY



Ten Plus Architectural Products Ltd. certifies that louver model RS7355 shown herein is licensed to bear the AMCA seal. The ratings shown are based on tests and procedures performed in accordance with AMCA Publication 511 and comply with the requirements of the AMCA Certified Ratings Program. The AMCA Certified Ratings Seal applies only to Air Performance, Water Penetration and Wind Driven Rain ratings.

Submission R7355 January 12, 2014
© Copyright 2014 Ten Plus Architectural Products Ltd.

Ten Plus Architectural Products Ltd. reserves the right to make design changes or to withdraw product without notice.

WIND DRIVEN RAIN PERFORMANCE

Core velocity - m/s (f/m)	0 (0)	0.6 (126)	1.0 (196)	1.4 (280)	1.9 (377)	2.4 (476)	3.0 (588)	3.5 (680)
Free area velocity - m/s (f/m)	0 (0)	1.1 (220)	1.7 (342)	2.5 (490)	3.4 (659)	4.2 (832)	5.2 (1027)	6.0 (1188)
Effectiveness classification	A	A	A	B	B	B	C	D
Effectiveness ratio	99.8%	99.6%	99.1%	98.7%	98.0%	95.1%	84.1%	71.3%

Discharge Loss Coefficient Class (Intake) = 3

This test is based on a 1 m x 1 m (39.37" x 39.37") louver core size, at a rainfall rate of 76mm/hr (3 in/hr), with wind driven rain applied to the face of the louver at a velocity of 13 m/s (29 mph). The above table shows the effectiveness against water penetration at each corresponding ventilation airflow rate.

MODEL R5455 STORM RESISTANT DRAINABLE LOUVER

PERFORMANCE

Performance Rating Standard	AMCA Standard 500L
Louver Type	Mullion Construction
Louver Depth	5" (127 mm)
Blade Angle	45°
Free Area – 4'x4' Unit	7.54 sq.ft. (0.70 m ²)
Percentage Free Area	47.1%
Free Area Velocity at Beginning Point of Water Penetration (0.01 oz / ft ²)	1100 FPM (5.59 m/s)
Air Volume at Beginning Point of Water Penetration 4' x 4' Unit (test duration of 15 minutes)	8294 CFM (4.0 m ³ /s)
Pressure Drop at Beginning Point of Water Penetration	0.40 in. H ₂ O (39.5 Pa)
Notes	Tested without bird screens
WIND DRIVEN RAIN WATER PENETRATION DATA (29 mph (13 m/s) wind velocity with a 3 in/hr (75 mm/hr) rainfall rate):	
Effectiveness Ratio: 99.8% (Class "A" Rating)	Core Ventilation Rate: 0.7 m/s (133 fpm) Free area velocity: 1.4 m/s (276 fpm)
Effectiveness Ratio: 98.9% (Class "B" Rating)	Core Ventilation Rate: 1.0 m/s (192 fpm) Free area velocity: 2 m/s (388 fpm)



VERTICAL SECTION



FLANGE FRAME
OPTIONAL



GLAZING FRAME
OPTIONAL

ABBREVIATED SPECIFICATION

Where indicated on drawings, supply and install 5" (127 mm) deep storm resistant louver Model R5455. Submit all details to consultant for approval prior to fabrication.

Head, sill, jambs and mullions shall have a minimum thickness of 0.080" (2.0 mm) 6063-T5 aluminum alloy. Jambs and Mullions shall have integral, vertical gutters to direct water to the bottom of the exterior face of the louver and away from the building. Blades shall be, 0.070" (1.77 mm) 6063-T5 aluminum alloy and include an integral horizontal gutter to lead water to the vertical gutters in the mullions and jambs provided with a sill pan flashing. Louvers shall be supplied with a 1/2" (12 mm), 19 gauge (1 mm) welded and regalvanized wire mesh in a mill finish, aluminum frame. Fasteners shall be standard zinc plated steel or stainless steel.

Materials Manufacturer: Ten Plus Architectural Products Ltd., 26 - 6535 Millcreek Drive, Mississauga, Ontario, Canada, L5N 2M2; Phone: (866) 884-0717; Email: info@tenplus-online.com; URL: www.tenplus-online.com

Structural supports shall be designed and furnished by the louver manufacturer to support a wind load of 20 psf (958 Pa), unless specified otherwise. Any louver opening greater than 10' (3 m) high, will require a horizontal girt, at mid span by others.

The louver manufacturer shall submit data, on a 4' x 4' (1.2 x 1.2 m) unit, showing that the louver performs to the above criteria, based on tests & procedures performed in accordance with the AMCA Publication 511, and comply with the "Certified Ratings Program" licensed to bear the AMCA seal.

Louvers shall be fabricated with mill finish aluminum and the finish shall be applied after assembly. Select desired finish from the following:

For superior performance, 3 coat PVDF system including a thermal setting application of 70% fluoropolymer resin. OR High performance 2 coat, PVDF system including a thermal setting application of 70% fluoropolymer resin. OR Pigmented Organic Thermal Setting Finish 1 coat system meeting or exceeding AAMA 2603. OR (Color Anodize) Ensure aluminum finish is colour anodized in accordance with Aluminum Association Finish Designation AA-M12C22A44, Class I, minimum 0.018 mm (0.7 mils) thick finish. Color to be selected by consultant. OR (Clear Anodize) Ensure aluminum finish is clear anodized in accordance with Aluminum Association Finish Designation AA-M12C22A41, Class I, minimum 0.018 mm (0.7 mils) thick for exterior applications and AA-12C22A31, Class II, minimum 0.01 mm (0.4 mils) thick for interior applications.

PERFORMANCE RATINGS – LOUVER MODEL R5455

FREE AREA CHART

		Louver Width				
		12	24	36	48	60
inches						
mm		305	610	914	1219	1524
Free Area - Square Feet / Square Meters						
12	0.27	0.60	0.92	1.25	1.58	
305	0.02	0.06	0.09	0.12	0.15	
24	0.66	1.46	2.27	3.08	3.89	
610	0.06	0.14	0.21	0.29	0.36	
36	1.13	2.52	3.91	5.31	6.70	
914	0.11	0.23	0.36	0.49	0.62	
48	1.71	3.81	5.91	7.54	10.11	
1219	0.16	0.35	0.55	0.70	0.94	
60	1.99	4.45	6.90	9.36	11.81	
1524	0.19	0.41	0.64	0.87	1.10	
72	2.47	5.51	8.55	11.58	14.62	
1829	0.23	0.51	0.79	1.08	1.36	
84	2.94	6.57	10.19	13.81	17.43	
2134	0.27	0.61	0.95	1.28	1.62	
96	3.52	7.86	12.19	16.52	20.86	
2438	0.33	0.73	1.13	1.54	1.94	
108	3.74	8.34	12.94	17.55	22.15	
2743	0.35	0.78	1.20	1.63	2.06	
120	4.20	9.37	14.54	19.71	24.88	
3048	0.39	0.87	1.35	1.83	2.31	
132	4.67	10.42	16.17	21.92	27.67	
3353	0.43	0.97	1.50	2.04	2.57	
144	5.51	11.48	17.81	24.14	30.48	
3658	0.48	1.07	1.66	2.24	2.83	

AIR FLOW RESISTANCE (TEST SIZE OF 4' X 4')

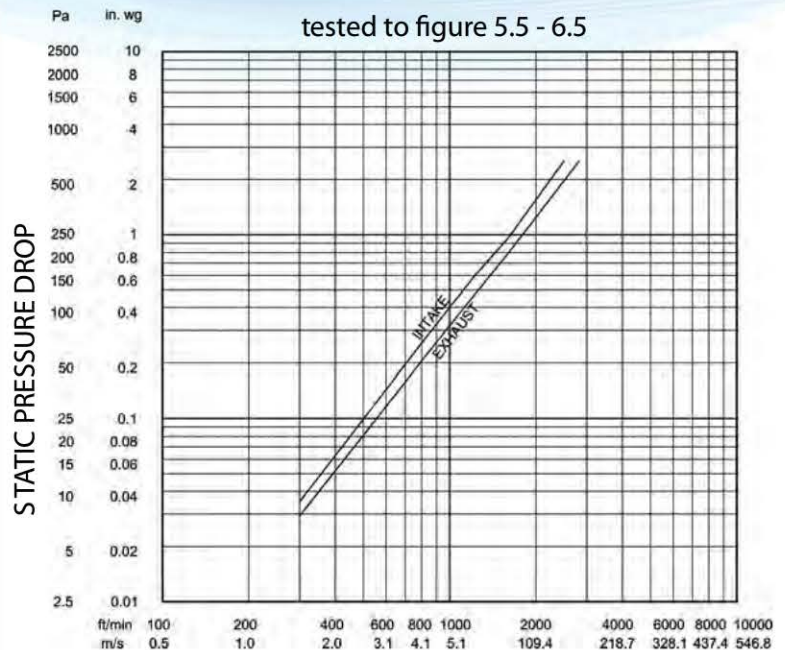

AIR VELOCITY



Ten Plus Architectural Products Ltd. certifies that louver model R5454 shown herein is licensed to bear the AMCA seal. The ratings shown are based on tests and procedures performed in accordance with AMCA Publication 511 and comply with the requirements of the AMCA Certified Ratings Program. The AMCA Certified Ratings Seal applies only to Air Performance, Water Penetration and Wind Driven Rain ratings.

Submission R5455 January 12, 2014
© Copyright 2014 Ten Plus Architectural Products Ltd.

Ten Plus Architectural Products Ltd. reserves the right to make design changes or to withdraw product without notice.

WIND DRIVEN RAIN PERFORMANCE

Core velocity - m/s (f/m)	0 (0)	0.7 (133)	1.0 (192)	1.4 (279)	1.9 (382)	2.4 (473)	3.0 (595)	3.5 (697)
Free area velocity - m/s (f/m)	0 (0)	1.4 (268)	2.0 (388)	2.9 (563)	3.9 (770)	4.8 (953)	6.1 (1199)	7.1 (1404)
Effectiveness classification	A	A	B	B	C	C	C	D
Effectiveness ratio	99.80%	99.40%	98.90%	97.20%	94.80%	92.30%	85.70%	74.70%

Discharge Loss Coefficient Class (Intake) = 3

This test is based on a 1 m x 1 m (39.37" x 39.37") louver core size, at a rainfall rate of 76mm/hr (3 in/hr), with wind driven rain applied to the face of the louver at a velocity of 13 m/s (29 mph). The above table shows the effectiveness against water penetration at each corresponding ventilation airflow rate.

MODEL D6403 DRAINABLE LOUVER

PERFORMANCE

Performance Rating Standard	AMCA Standard 500L
Louver Type	Mullion or Continuous Line Construction
Louver Depth	6" (152 mm)
Blade Angle	40°
Free Area – 4'x4' Unit	9.01 sq.ft. (0.837 m ²)
Percentage Free Area	56.3%
Free Area Velocity at Beginning Point of Water Penetration (0.01 oz / ft ²)	969.9 FPM (4.93 m/s)
Air Volume at Beginning Point of Water Penetration 4' x 4' Unit (test duration of 15 minutes)	8739 CFM (4.12 m ³ /s)
Pressure Drop at Beginning Point of Water Penetration	0.16 in. H ₂ O (39.5 Pa)
Notes	Tested without bird screens

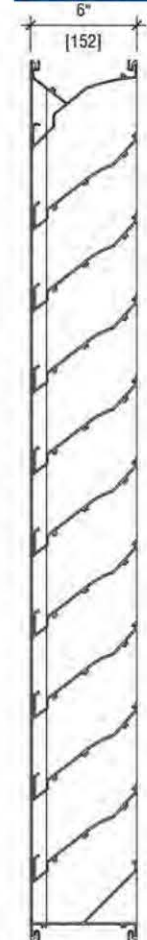

VERTICAL SECTION

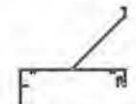

FLANGE FRAME
OPTIONAL

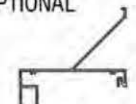

GLAZING FRAME
OPTIONAL

ABBREVIATED SPECIFICATION

Where indicated on drawings, supply and install 6" (152 mm) deep, drainable louver Model D6403. Submit all details to consultant for approval prior to fabrication. Head, sill, jambs and mullions shall have a minimum thickness of 0.080" (2.0 mm) 6063-T5 aluminum alloy.

Jambs and Mullions shall have integral, vertical gutters to direct water to the bottom of the exterior face of the louver and away from the building. Blades shall be, 0.090" (2.3 mm) 6063-T5 aluminum alloy and include an integral horizontal gutter to lead water to the vertical gutters in the mullions and jambs. Louvers shall be supplied with a 1/2" (12 mm), 19 gauge (1 mm) welded and regalvanized wire mesh in a mill finish, aluminum frame. Fasteners shall be standard zinc plated steel or stainless steel.

Materials Manufacturer: Ten Plus Architectural Products Ltd., 26 - 6535 Millcreek Drive, Mississauga, Ontario, Canada, L5N 2M2; Phone: (866) 884-0717; Email: info@tenplus-online.com; URL: www.tenplus-online.com

Structural supports shall be designed and furnished by the louver manufacturer to support a wind load of 20 psf (958 Pa), unless specified otherwise. Any louver opening greater than 10' (3 m) high, will require a horizontal girt, at mid span by others.

The louver manufacturer shall submit data, on a 4' x 4' (1.2 x 1.2 m) unit, showing that the louver performs to the following criteria, based on tests & procedures performed in accordance with the AMCA Publication 511, and comply with the "Certified Ratings Program" licensed to bear the AMCA seal:

Free area = 9.01 sq.ft. (0.837 m²)

Free area velocity at point of beginning water penetration = 969.9 FPM (4.93 m/s)

Intake pressure drop at beginning point of water penetration = 0.16 in. H₂O (39.5 Pa)

Louvers shall be fabricated with mill finish aluminum and the finish shall be applied after assembly. Select desired finish from the following:

For superior performance, 3 coat PVDF system including a thermal setting application of 70% fluoropolymer resin. OR High performance 2 coat, PVDF system including a thermal setting application of 70% fluoropolymer resin. OR Pigmented Organic Thermal Setting Finish 1 coat system meeting or exceeding AAMA 2603. OR (Color Anodize) Ensure aluminum finish is colour anodized in accordance with Aluminum Association Finish Designation AA-M12C22A44, Class I, minimum 0.018 mm (0.7 mils) thick finish. Color to be selected by consultant. OR (Clear Anodize) Ensure aluminum finish is clear anodized in accordance with Aluminum Association Finish Designation AA-M12C22A41, Class I, minimum 0.018 mm (0.7 mils) thick for exterior applications and AA-12C22A31, Class II, minimum 0.01 mm (0.4 mils) thick for interior applications.



PERFORMANCE RATINGS – LOUVER MODEL D6403

FREE AREA CHART

		Louver Width				
		12	24	36	48	60
inches	mm	305	610	914	1219	1524
Free Area - Square Feet / Square Meters						
12	305	0.30 / 0.03	0.67 / 0.06	1.04 / 0.10	1.40 / 0.13	1.77 / 0.16
24	610	0.78 / 0.07	1.75 / 0.16	2.71 / 0.25	3.67 / 0.34	4.64 / 0.43
36	914	1.38 / 0.13	3.07 / 0.29	4.76 / 0.44	6.46 / 0.60	8.15 / 0.76
48	1219	1.86 / 0.17	4.15 / 0.39	6.44 / 0.60	8.72 / 0.81	11.02 / 1.02
60	1524	2.45 / 0.23	5.47 / 0.51	8.49 / 0.79	11.51 / 1.07	14.52 / 1.35
72	1829	2.94 / 0.27	6.55 / 0.61	10.17 / 0.94	13.78 / 1.28	17.40 / 1.62
84	2134	3.42 / 0.32	7.63 / 0.71	11.84 / 1.10	16.05 / 1.49	20.27 / 1.88
96	2438	4.01 / 0.37	8.95 / 0.83	13.89 / 1.29	18.84 / 1.75	23.78 / 2.21
108	2743	4.50 / 0.42	10.03 / 0.93	15.57 / 1.45	21.11 / 1.96	26.64 / 2.48
120	3048	4.98 / 0.46	11.11 / 1.03	17.25 / 1.60	23.38 / 2.17	29.51 / 2.74
132	3353	5.58 / 0.52	12.44 / 1.16	19.30 / 1.79	26.16 / 2.43	33.02 / 3.07
144	3658	6.06 / 0.56	13.52 / 1.26	20.98 / 1.95	28.43 / 2.64	35.89 / 3.34

AIR FLOW RESISTANCE (TEST SIZE OF 4' X 4')

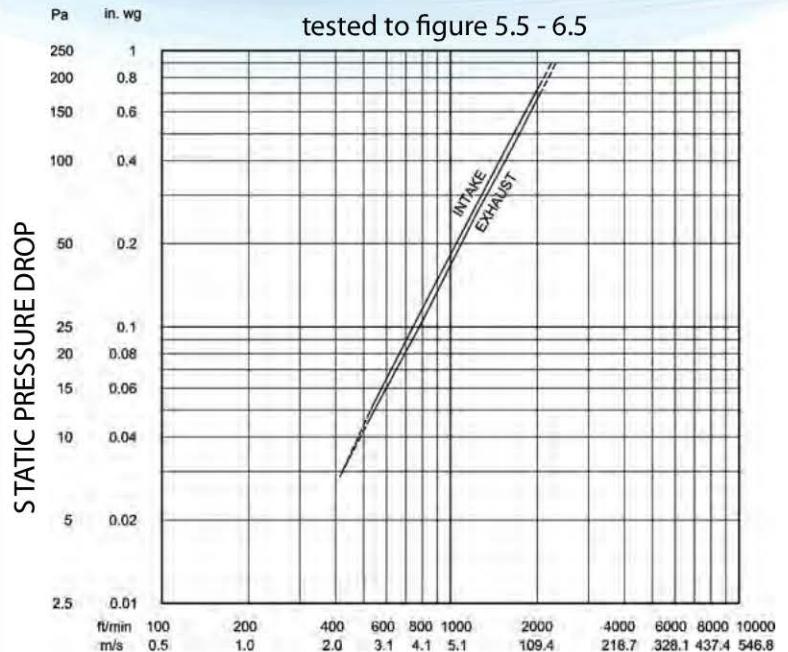

AIR VELOCITY



Ten Plus Architectural Products Ltd. certifies that louver model D6403 shown herein is licensed to bear the AMCA seal. The ratings shown are based on tests and procedures performed in accordance with AMCA Publication 511 and comply with the requirements of the AMCA Certified Ratings Program. The AMCA Certified Ratings Seal applies only to Air Performance, Water Penetration ratings.

Submittal D6403 January 12, 2014
© Copyright 2014 Ten Plus Architectural Products Ltd.

Ten Plus Architectural Products Ltd. reserves the right to make design changes or to withdraw product without notice.

MODEL D4493 DRAINABLE LOUVER

PERFORMANCE

Performance Rating Standard	AMCA Standard 500L
Louver Type	Mullion or Continuous Line Construction
Louver Depth	4" (102 mm)
Blade Angle	49°
Free Area – 4'x4' Unit	7.68 sq.ft. (0.714 m ²)
Percentage Free Area	48%
Free Area Velocity at Beginning Point of Water Penetration (0.01 oz / ft ²)	1033.2 FPM (5.25 m/s)
Air Volume at Beginning Point of Water Penetration 4' x 4' Unit (test duration of 15 minutes)	7935 CFM (3.75 m ³ /s)
Pressure Drop at Beginning Point of Water Penetration	0.25 in. H ₂ O (62.3 Pa)
Notes	Tested without bird screens

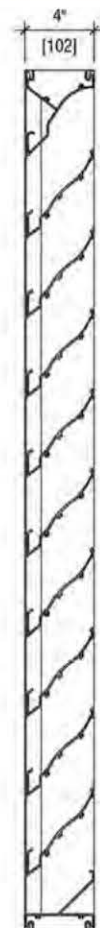

VERTICAL SECTION

ABBREVIATED SPECIFICATION

Where indicated on drawings, supply and install 4" (102 mm) deep, drainable louver Model D4493. Submit all details to consultant for approval prior to fabrication. Head, sill, jambs and mullions shall have a minimum thickness of 0.080" (2.0 mm) 6063-T5 aluminum alloy.

Jambs and Mullions shall have integral, vertical gutters to direct water to the bottom of the exterior face of the louver and away from the building. Blades shall be 0.080" (2.0 mm) 6063-T5 aluminum alloy and include an integral horizontal gutter to lead water to the vertical gutters in the mullions and jambs. Louvers shall be supplied with a 1/2" (12 mm), 19 gauge (1 mm) welded and regalvanized wire mesh in a mill finish, aluminum frame. Fasteners shall be standard zinc plated steel or stainless steel.

Materials Manufacturer: Ten Plus Architectural Products Ltd., 26 - 6535 Millcreek Drive, Mississauga, Ontario, Canada, L5N 2M2; Phone: (866) 884-0717; Email: info@tenplus-online.com; URL: www.tenplus-online.com

Structural supports shall be designed and furnished by the louver manufacturer to support a wind load of 20 psf (958 Pa), unless specified otherwise. Any louver opening greater than 10' (3 m) high, will require a horizontal girt, at mid span by others.

The louver manufacturer shall submit data, on a 4' x 4' (1.2 x 1.2 m) unit, showing that the louver performs to the following criteria, based on tests & procedures performed in accordance with the AMCA Publication 511, and comply with the "Certified Ratings Program" licensed to bear the AMCA seal:

- Free area = 7.68 sq. ft. (0.714 m²)
- Free area velocity at point of beginning water penetration = 1033.2 FPM (5.25 m/s)
- Intake pressure drop at beginning point of water penetration = 0.25 in. H₂O (62.3 Pa)

Louvers shall be fabricated with mill finish aluminum and the finish shall be applied after assembly. Select desired finish from the following:

For superior performance, 3 coat PVDF system including a thermal setting application of 70% fluoropolymer resin. OR High performance 2 coat, PVDF system including a thermal setting application of 70% fluoropolymer resin. OR Pigmented Organic Thermal Setting Finish 1 coat system meeting or exceeding AAMA 2603. OR (Color Anodize) Ensure aluminum finish is colour anodized in accordance with Aluminum Association Finish Designation AA-M12C22A44, Class I, minimum 0.018 mm (0.7 mils) thick finish. Color to be selected by consultant. OR (Clear Anodize) Ensure aluminum finish is clear anodized in accordance with Aluminum Association Finish Designation AA-M12C22A41, Class I, minimum 0.018 mm (0.7 mils) thick for exterior applications and AA-12C22A31, Class II, minimum 0.01 mm (0.4 mils) thick for interior applications.

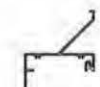

FLANGE FRAME
OPTIONAL



GLAZING FRAME
OPTIONAL

PERFORMANCE RATINGS – LOUVER MODEL D4493

FREE AREA CHART

		Louver Width				
		12	24	36	48	60
inches	mm	305	610	914	1219	1524
Free Area - Square Feet / Square Meters						
12	305	0.30 / 0.03	0.67 / 0.06	1.05 / 0.10	1.42 / 0.13	1.79 / 0.17
24	610	0.70 / 0.07	1.57 / 0.15	2.44 / 0.23	3.30 / 0.31	4.17 / 0.39
36	914	1.23 / 0.11	2.74 / 0.25	4.25 / 0.39	5.76 / 0.54	7.27 / 0.68
48	1219	1.62 / 0.15	3.62 / 0.34	5.61 / 0.52	7.68 / 0.71	9.60 / 0.89
60	1524	2.15 / 0.20	4.80 / 0.45	7.45 / 0.69	10.10 / 0.94	12.75 / 1.19
72	1829	2.55 / 0.24	5.68 / 0.53	8.82 / 0.82	11.95 / 1.11	15.08 / 1.40
84	2134	2.94 / 0.27	6.56 / 0.61	10.18 / 0.95	13.80 / 1.28	17.42 / 1.62
96	2438	3.47 / 0.32	7.75 / 0.72	12.02 / 1.12	16.29 / 1.51	20.57 / 1.91
108	2743	3.87 / 0.36	8.62 / 0.80	13.38 / 1.24	18.14 / 1.69	22.90 / 2.13
120	3048	4.57 / 0.42	10.20 / 0.95	15.83 / 1.47	21.45 / 1.99	27.08 / 2.52
132	3353	4.79 / 0.45	10.69 / 0.99	16.59 / 1.54	22.49 / 2.09	28.38 / 2.64
144	3658	5.19 / 0.48	11.57 / 1.08	17.96 / 1.67	24.34 / 2.26	30.72 / 2.86

AIR FLOW RESISTANCE (TEST SIZE OF 4' X 4')

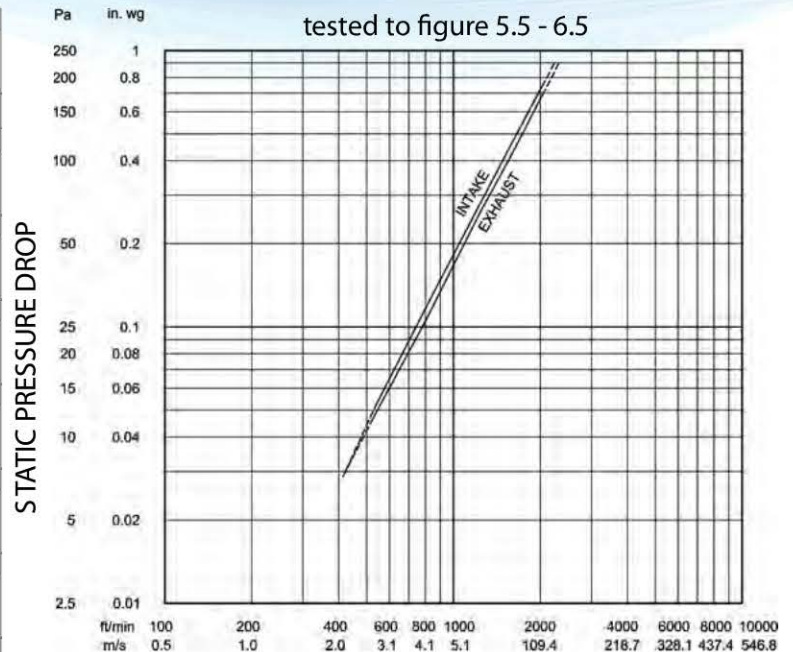

AIR VELOCITY



Ten Plus Architectural Products Ltd. certifies that louver model D4493 shown herein is licensed to bear the AMCA seal. The ratings shown are based on tests and procedures performed in accordance with AMCA Publication 511 and comply with the requirements of the AMCA Certified Ratings Program. The AMCA Certified Ratings Seal applies only to Air Performance, Water Penetration ratings.

Submittal D4493 January 12, 2014
© Copyright 2014 Ten Plus Architectural Products Ltd.

Ten Plus Architectural Products Ltd. reserves the right to make design changes or to withdraw product without notice.

MODEL H6451 STORM BLADE LOUVER

PERFORMANCE

Performance Rating Standard	AMCA Standard 500L
Louver Type	Mullion or Continuous Line Construction
Louver Depth	6" (152 mm)
Blade Angle	45°
Free Area – 4'x4' Unit	7.53 sq.ft. (0.700 m ²)
Percentage Free Area	47.1%
Free Area Velocity at Beginning Point of Water Penetration (0.01 oz / ft ²)	653 FPM (3.32m/s)
Air Volume at Beginning Point of Water Penetration 4' x 4' Unit (test duration of 15 minutes)	4917 CFM (2.32 m ³ /s)
Pressure Drop at Beginning Point of Water Penetration	0.067 in. H ₂ O (16.69 Pa)
Notes	Tested without bird screens

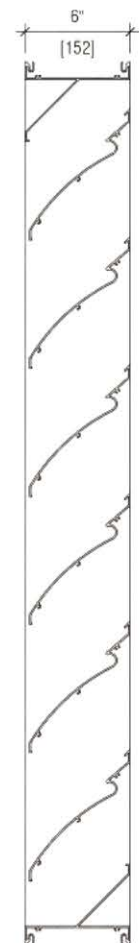

VERTICAL SECTION

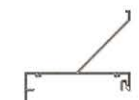

FLANGE FRAME
OPTIONAL



GLAZING FRAME
OPTIONAL

SUGGESTED SPECIFICATION

Where indicated on drawings, supply and install 6" (152 mm) deep storm blade louver Model H6451. Submit all details to consultant for approval prior to fabrication. Head, sill, jambs and mullions shall have a minimum thickness of 0.080" (2.0 mm) 6063-T5 aluminum alloy.

Blades shall be continuous, 0.090" (2.3 mm) 6063-T5 aluminum alloy with a storm hook design. Louvers shall be supplied with a 1/2" (12 mm), 19 gauge (1 mm) welded and regalvanized wire mesh in a mill finish, aluminum frame. Fasteners shall be standard zinc plated steel or stainless steel.

Materials Manufacturer: Ten Plus Architectural Products Ltd., 26 - 6535 Millcreek Drive, Mississauga, Ontario, Canada, L5N 2M2; Phone: (866) 884-0717; Email: info@tenplus-online.com; URL: www.tenplus-online.com

Structural supports shall be designed and furnished by the louver manufacturer to support a wind load of 20 psf (958 Pa), unless specified otherwise. Any louver opening greater than 10' (3 m) high, will require a horizontal girt, at mid span by others.

The louver manufacturer shall submit data, on a 4' x 4' (1.2 x 1.2 m) unit, showing that the louver performs to the following criteria, based on tests & procedures performed in accordance with the AMCA Publication 511, and comply with the "Certified Ratings Program" licensed to bear the AMCA seal:

Free area = 7.53 sq. ft. (0.700 m²)

Free area velocity at point of beginning water penetration = 653 FPM (3.32 m/s)

Intake pressure drop at beginning point of water penetration = 0.067 in. H₂O (16.69 Pa)

Louvers shall be fabricated with mill finish aluminum and the finish shall be applied after assembly. Select desired finish from the following:

For superior performance, 3 coat PVDF system including a thermal setting application of 70% fluoropolymer resin. OR High performance 2 coat, PVDF system including a thermal setting application of 70% fluoropolymer resin. OR Pigmented Organic Thermal Setting Finish 1 coat system meeting or exceeding AAMA 2603. OR (Color Anodize) Ensure aluminum finish is colour anodized in accordance with Aluminum Association Finish Designation AA-M12C22A44, Class I, minimum 0.018 mm (0.7 mils) thick finish. Color to be selected by consultant. OR (Clear Anodize) Ensure aluminum finish is clear anodized in accordance with Aluminum Association Finish Designation AA-M12C22A41, Class I, minimum 0.018 mm (0.7 mils) thick for exterior applications and AA-12C22A31, Class II, minimum 0.01 mm (0.4 mils) thick for interior applications.



PERFORMANCE RATINGS – LOUVER MODEL H6451

FREE AREA CHART

		Louver Width				
		12	24	36	48	60
inches	mm	305	610	914	1219	1524
Free Area - Square Feet / Square Meters						
12		0.18	0.39	0.60	0.81	1.02
305		0.02	0.04	0.06	0.08	0.09
24		0.59	1.30	2.01	2.73	3.44
610		0.06	0.12	0.19	0.25	0.32
36		1.22	2.69	4.15	5.62	7.08
914		0.11	0.25	0.39	0.52	0.66
48		1.64	3.61	5.58	7.53	9.51
1219		0.15	0.34	0.52	0.70	0.88
60		2.27	4.99	7.71	10.42	13.14
1524		0.21	0.46	0.72	0.97	1.22
72		2.69	5.91	9.13	12.35	15.57
1829		0.25	0.55	0.85	1.15	1.45
84		3.10	6.83	10.56	14.28	18.01
2134		0.29	0.63	0.98	1.33	1.67
96		3.73	8.21	12.68	17.16	21.64
2438		0.35	0.76	1.18	1.59	2.01
108		4.15	9.13	14.11	19.09	24.07
2743		0.39	0.85	1.31	1.77	2.24
120		4.57	10.05	15.53	21.01	26.50
3048		0.42	0.93	1.44	1.95	2.46
132		5.19	11.43	17.66	23.90	30.13
3353		0.48	1.06	1.64	2.22	2.80
144		5.61	12.35	19.09	25.82	32.56
3658		0.52	1.15	1.77	2.40	3.03

AIR FLOW RESISTANCE (TEST SIZE OF 4' X 4')

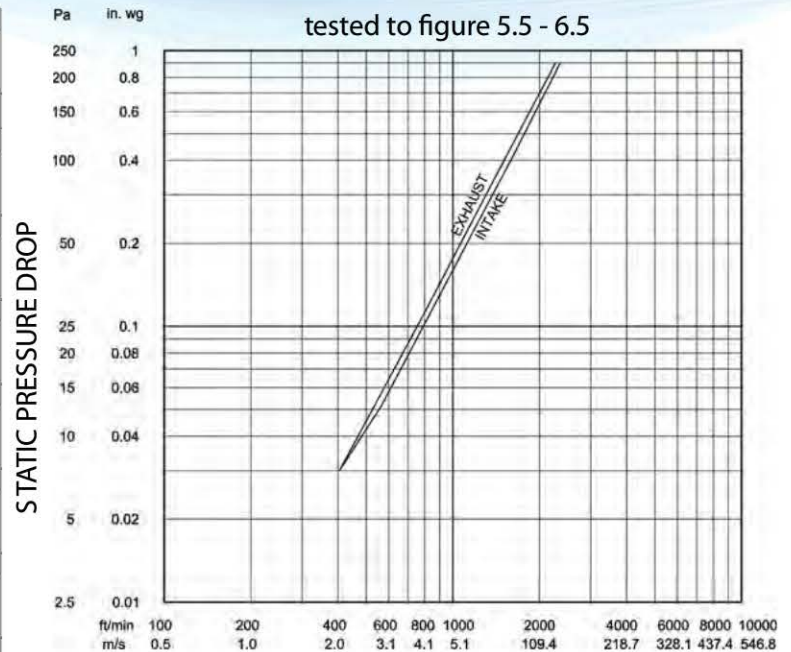

AIR VELOCITY



Ten Plus Architectural Products Ltd. certifies that louver model H6451 shown herein is licensed to bear the AMCA seal. The ratings shown are based on tests and procedures performed in accordance with AMCA Publication 511 and comply with the requirements of the AMCA Certified Ratings Program. The AMCA Certified Ratings Seal applies only to Air Performance, Water Penetration ratings.

Submittal H6451 January 12, 2014
© Copyright 2014 Ten Plus Architectural Products Ltd.

Ten Plus Architectural Products Ltd. reserves the right to make design changes or to withdraw product without notice.

MODEL H4451 STORM BLADE LOUVER

PERFORMANCE

Performance Rating Standard	AMCA Standard 500L
Louver Type	Mullion or Continuous Line Construction
Louver Depth	4" (102 mm)
Blade Angle	45°
Free Area – 4'x4' Unit	8.12 sq.ft. (0.755 m ²)
Percentage Free Area	51%
Free Area Velocity at Beginning Point of Water Penetration (0.01 oz / ft ²)	658 FPM (3.34 m/s)
Air Volume at Beginning Point of Water Penetration 4' x 4' Unit (test duration of 15 minutes)	5343 CFM (2.52 m ³ /s)
Pressure Drop at Beginning Point of Water Penetration	.077 in. H ₂ O (19.18 Pa)
Notes	Tested without bird screens



VERTICAL SECTION

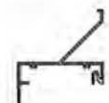

FLANGE FRAME
OPTIONAL

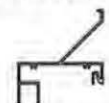

GLAZING FRAME
OPTIONAL

ABBREVIATED SPECIFICATION

Where indicated on drawings, supply and install 4" (102 mm) deep storm blade louver Model H4451. Submit all details to consultant for approval prior to fabrication. Head, sill, jambs and mullions shall have a minimum thickness of 0.080" (2.0 mm) 6063-T5 aluminum alloy.

Blades shall be continuous, 0.080" (2.0 mm) 6063-T5 aluminum alloy with a storm hook design. Louvers shall be supplied with a 1/2" (12 mm), 19 gauge (1 mm) welded and regalvanized wire mesh in a mill finish, aluminum frame. Fasteners shall be standard zinc plated steel or stainless steel.

Materials Manufacturer: Ten Plus Architectural Products Ltd., 26 - 6535 Millcreek Drive, Mississauga, Ontario, Canada, L5N 2M2; Phone: (866) 884-0717; Email: info@tenplus-online.com; URL: www.tenplus-online.com

Structural supports shall be designed and furnished by the louver manufacturer to support a wind load of 20 psf (958Pa), unless specified otherwise. Any louver opening greater than 10' (3 m) high, will require a horizontal girt, at mid span by others.

The louver manufacturer shall submit data, on a 4' x 4' (1.2 x 1.2 m) unit, showing that the louver performs to the following criteria, based on tests & procedures performed in accordance with the AMCA Publication 511, and comply with the "Certified Ratings Program" licensed to bear the AMCA seal:

Free area = 8.12 sq. ft. (0.755 m²)

Free area velocity at point of beginning water penetration = 658 FPM (3.34 m/s)

Intake pressure drop at beginning point of water penetration = 0.077 in. H₂O (19.18 Pa)

Louvers shall be fabricated with mill finish aluminum and the finish shall be applied after assembly. Select desired finish from the following:

For superior performance, 3 coat PVDF system including a thermal setting application of 70% fluoropolymer resin. OR High performance 2 coat, PVDF system including a thermal setting application of 70% fluoropolymer resin. OR Pigmented Organic Thermal Setting Finish 1 coat system meeting or exceeding AAMA 2603. OR (Color Anodize) Ensure aluminum finish is colour anodized in accordance with Aluminum Association Finish Designation AA-M12C22A44, Class I, minimum 0.018 mm (0.7 mils) thick finish. Color to be selected by consultant. OR (Clear Anodize) Ensure aluminum finish is clear anodized in accordance with Aluminum Association Finish Designation AA-M12C22A41, Class I, minimum 0.018 mm (0.7 mils) thick for exterior applications and AA-12C22A31, Class II, minimum 0.01 mm (0.4 mils) thick for interior applications.



PERFORMANCE RATINGS – LOUVER MODEL H4451

FREE AREA CHART

		Louver Width				
		12	24	36	48	60
inches	mm	305	610	914	1219	1524
Free Area - Square Feet / Square Meters						
12		0.30	0.73	1.13	1.53	1.92
305		0.03	0.07	0.10	0.14	0.18
24		0.74	1.62	2.51	3.40	4.28
610		0.07	0.15	0.23	0.32	0.40
36		1.29	2.83	4.38	5.92	7.46
914		0.12	0.26	0.41	0.55	0.69
48		1.78	3.92	6.05	8.12	10.32
1219		0.17	0.36	0.56	0.75	0.96
60		2.24	4.93	7.62	10.31	13.00
1524		0.21	0.46	0.71	0.96	1.21
72		2.79	6.14	9.49	12.84	16.19
1829		0.26	0.57	0.88	1.19	1.50
84		3.45	7.60	11.74	15.89	20.03
2134		0.32	0.71	1.09	1.48	1.86
96		3.75	8.24	12.74	17.23	21.73
2438		0.35	0.77	1.18	1.60	2.02
108		4.15	9.14	14.12	19.10	24.08
2743		0.39	0.85	1.31	1.78	2.24
120		4.70	10.34	15.98	21.63	27.27
3048		0.44	0.96	1.49	2.01	2.53
132		5.25	11.55	17.85	24.15	30.45
3353		0.49	1.07	1.66	2.24	2.83
144		5.66	12.44	19.23	26.02	32.81
3658		0.53	1.16	1.79	2.42	3.05

AIR FLOW RESISTANCE (TEST SIZE OF 4' X 4')

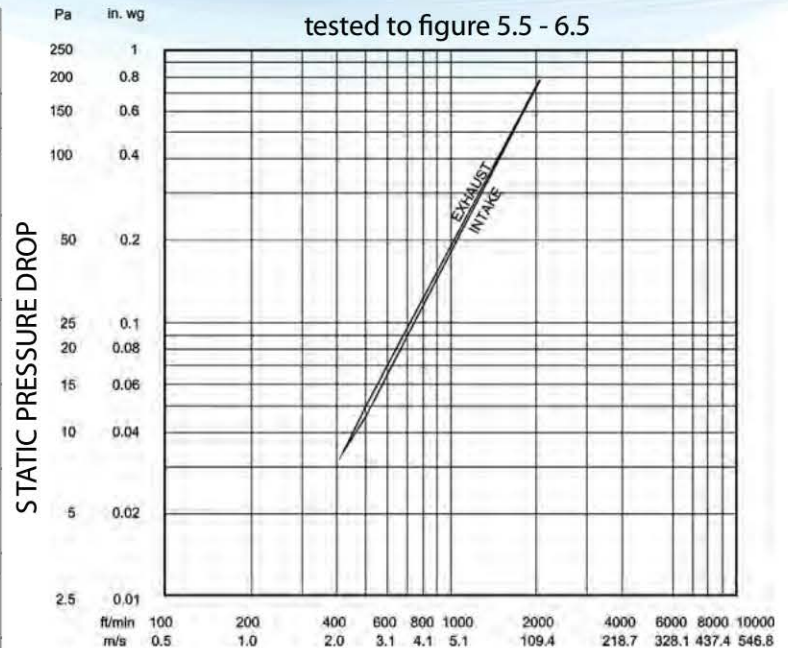

AIR VELOCITY



Ten Plus Architectural Products Ltd. certifies that louver model H4451 shown herein is licensed to bear the AMCA seal. The ratings shown are based on tests and procedures performed in accordance with AMCA Publication 511 and comply with the requirements of the AMCA Certified Ratings Program. The AMCA Certified Ratings Seal applies only to Air Performance, Water Penetration and Wind Driven Rain ratings.

Submission H4451 January 12, 2014
© Copyright 2014 Ten Plus Architectural Products Ltd.

Ten Plus Architectural Products Ltd. reserves the right to make design changes or to withdraw product without notice.

MODEL S6452 STRAIGHT BLADE LOUVER

PERFORMANCE

Louver Type	Mullion or Continuous Line Construction
Louver Depth	6" (152 mm)
Blade Angle	45°
Free Area – 4'x4' Unit	7.44 sq.ft. (0.692 m ²)
Percentage Free Area	46.5%

ABBREVIATED SPECIFICATION

Where indicated on drawings, supply and install 6" (152 mm) deep straight blade louver Model S6452. Submit all details to consultant for approval prior to fabrication. Head, sill, jambs and mullions shall have a minimum thickness of 0.090" (2.3 mm) 6063-T5 aluminum alloy.

Blades shall be continuous, 0.090" (2.3 mm) 6063-T5 aluminum alloy. Louvers shall be supplied with a 1/2" (12 mm), 19 gauge (1 mm) welded and regalvanized wire mesh in a mill finish, aluminum frame. Fasteners shall be standard zinc plated steel or stainless steel.

Materials Manufacturer: Ten Plus Architectural Products Ltd., 26 - 6535 Millcreek Drive, Mississauga, Ontario, Canada, L5N 2M2; Phone: (866) 884-0717; Email: info@tenplus-online.com; URL: www.tenplus-online.com

Structural supports shall be designed and furnished by the louver manufacturer to support a wind load of 20 psf (955 Pa), unless specified otherwise. Any louver opening greater than 10' (3 m) high, will require a horizontal girt, at mid span by others.

Louvers shall be fabricated with mill finish aluminum and the finish shall be applied after assembly. Select desired finish from the following:

For superior performance, 3 coat PVDF system including a thermal setting application of 70% fluoropolymer resin. OR High performance 2 coat, PVDF system including a thermal setting application of 70% fluoropolymer resin. OR Pigmented Organic Thermal Setting Finish 1 coat system meeting or exceeding AAMA 2603. OR (Color Anodize) Ensure aluminum finish is colour anodized in accordance with Aluminum Association Finish Designation AA-M12C22A44, Class I, minimum 0.018 mm (0.7 mils) thick finish. Color to be selected by consultant. OR (Clear Anodize) Ensure aluminum finish is clear anodized in accordance with Aluminum Association Finish Designation AA-M12C22A41, Class I, minimum 0.018 mm (0.7 mils) thick for exterior applications and AA-12C22A31, Class II, minimum 0.01 mm (0.4 mils) thick for interior applications.

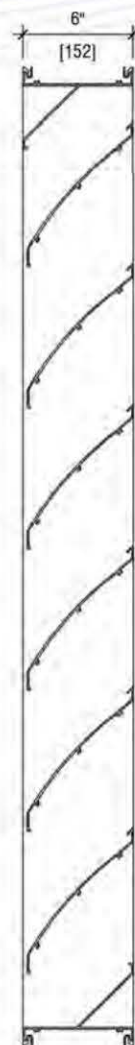

VERTICAL SECTION

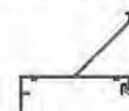

FLANGE FRAME
OPTIONAL

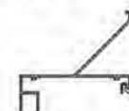

GLAZING FRAME
OPTIONAL



FREE AREA CHART

		Louver Width				
		12	24	36	48	60
inches						
mm		305	610	914	1219	1524
Free Area - Square Feet / Square Meters						
Louver Height	12	0.14	0.32	0.49	0.66	0.83
	305	0.01	0.03	0.05	0.06	0.08
	24	0.72	1.59	2.45	3.31	4.18
	610	0.07	0.15	0.23	0.31	0.39
	36	1.04	2.29	3.54	4.79	6.04
	914	0.10	0.21	0.33	0.44	0.56
	48	1.62	3.56	5.50	7.44	9.38
	1219	0.15	0.33	0.51	0.69	0.87
	60	1.94	4.26	6.59	8.92	11.24
	1524	0.18	0.40	0.61	0.83	1.04
	72	2.52	5.53	8.55	11.57	14.59
	1829	0.23	0.51	0.79	1.08	1.36
	84	2.84	6.24	9.64	13.04	16.45
	2134	0.26	0.58	0.90	1.21	1.53
	96	3.16	6.94	10.73	14.52	18.30
	2438	0.29	0.65	1.00	1.35	1.70
108	3.73	8.21	12.69	17.17	21.65	
2743	0.35	0.76	1.18	1.60	2.01	
120	4.05	8.92	13.78	18.64	23.51	
3048	0.38	0.83	1.28	1.73	2.18	
132	4.63	10.19	15.74	21.30	26.85	
3353	0.43	0.95	1.46	1.98	2.50	
144	4.95	10.89	16.83	22.77	28.71	
3658	0.46	1.01	1.56	2.12	2.67	

MODEL V4454 SIGHT PROOF BLADE

PERFORMANCE

Louver Type	Mullion or Continuous Line Construction
Louver Depth	4" (102 mm)
Blade Angle	45°

ABBREVIATED SPECIFICATION

Where indicated on drawings, supply and install 4" (102 mm) deep sight proof louver Model V4454. Submit all details to consultant for approval prior to fabrication. Head, sill, jambs and mullions shall have a minimum thickness of 0.080" (2. mm) 6063-T5 aluminum alloy.

Blades shall be continuous, 0.080" (2 mm) 6063-T5 aluminum alloy. Louvers shall be supplied with a 1/2" (12 mm), 19 gauge (1 mm) welded and regalvanized wire mesh in a mill finish, aluminum frame. Fasteners shall be standard zinc plated steel or stainless steel.

Materials Manufacturer: Ten Plus Architectural Products Ltd., 26 - 6535 Millcreek Drive, Mississauga, Ontario, Canada, L5N 2M2; Phone: (866) 884-0717; Email: info@tenplus-online.com; URL: www.tenplus-online.com

Structural supports shall be designed and furnished by the louver manufacturer to support a wind load of 20 psf (958 Pa), unless specified otherwise. Any louver opening greater than 10' (3 m) high, will require a horizontal girt, at mid span by others.

Louvers shall be fabricated with mill finish aluminum and the finish shall be applied after assembly. Select desired finish from the following:

For superior performance, 3 coat PVDF system including a thermal setting application of 70% fluoropolymer resin. OR High performance 2 coat, PVDF system including a thermal setting application of 70% fluoropolymer resin. OR Pigmented Organic Thermal Setting Finish 1 coat system meeting or exceeding AAMA 2603. OR (Color Anodize) Ensure aluminum finish is colour anodized in accordance with Aluminum Association Finish Designation AA-M12C22A44, Class I, minimum 0.018 mm (0.7 mils) thick finish. Color to be selected by consultant. OR (Clear Anodize) Ensure aluminum finish is clear anodized in accordance with Aluminum Association Finish Designation AA-M12C22A41, Class I, minimum 0.018 mm (0.7 mils) thick for exterior applications and AA-12C22A31, Class II, minimum 0.01 mm (0.4 mils) thick for interior applications.

NB:

The V4454 blade is an adaptation of the of the H4451 storm blade and the front of the blades are identical. The intention is to maintain and extend the blade lines from a louver to a vision screen in situations where they are adjacent or in proximity to each other.



VERTICAL SECTION

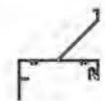

FLANGE FRAME
OPTIONAL

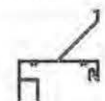

GLAZING FRAME
OPTIONAL



FREE AREA CHART

		Louver Width				
		12	24	36	48	60
inches						
mm		305	610	914	1219	1524
Free Area - Square Feet / Square Meters						
Louver Height	12	0.16	0.36	0.55	0.74	0.94
	305	0.02	0.03	0.05	0.07	0.09
	24	0.43	0.95	1.46	1.98	2.49
	610	0.04	0.09	0.14	0.18	0.23
	36	0.76	1.67	2.59	3.50	4.41
	914	0.07	0.16	0.24	0.33	0.41
	48	0.94	2.06	3.18	4.31	5.43
	1219	0.09	0.19	0.30	0.40	0.50
	60	1.27	2.79	4.31	5.83	7.35
	1524	0.12	0.26	0.40	0.54	0.68
	72	1.43	3.16	4.88	6.60	8.32
	1829	0.13	0.29	0.45	0.61	0.77
	84	1.75	3.85	5.95	8.05	10.15
	2134	0.16	0.36	0.55	0.75	0.94
	96	1.94	4.26	6.58	8.91	11.23
	2438	0.18	0.40	0.61	0.83	1.04
108	2.25	4.95	7.64	10.34	13.04	
2743	0.21	0.46	0.71	0.96	1.21	
120	2.44	5.38	8.31	11.24	14.18	
3048	0.38	0.83	1.28	1.73	1.32	
132	2.83	6.22	9.61	13.00	16.39	
3353	0.26	0.58	0.89	1.21	1.52	
144	3.01	6.63	10.25	13.86	17.48	
3658	0.28	0.62	0.95	1.29	1.62	

MODEL H2451 STORM BLADE LOUVER

PERFORMANCE

Louver Type	Mullion or Continuous Line Construction
Louver Depth	2" (51 mm)
Blade Angle	45°
Free Area – 4'x4' Unit	6.78 sq.ft. (0.639 m ²)
Percentage Free Area	43%

ABBREVIATED SPECIFICATION

Where indicated on drawings, supply and install 2" (51 mm) deep, storm blade louver Model H2451. Submit all details to consultant for approval prior to fabrication. Head, sill, jambs and mullions shall have a nominal thickness of 0.062" (1.57 mm) 6063-T5 aluminum alloy.

Blades shall be continuous, 0.062" (1.57 mm) thick 6063-T5 aluminum alloy. Louvers shall be supplied with a 1/2" (12 mm), 19 gauge (1 mm) welded and regalvanized wire mesh in a mill finish, aluminum frame. Fasteners shall be standard zinc plated steel or stainless steel.

Materials Manufacturer: Ten Plus Architectural Products Ltd., 26 - 6535 Millcreek Drive, Mississauga, Ontario, Canada, L5N 2M2; Phone: (866) 884-0717; Email: info@tenplus-online.com; URL: www.tenplus-online.com

Structural supports shall be designed and furnished by the Louver manufacturer to support a wind load of 20 psf (958 Pa), unless specified otherwise. Any Louver opening greater than 10' (3 m) high, will require a horizontal girt, at mid span by others.

Louvers shall be fabricated with mill finish aluminum and the finish shall be applied after assembly. Select desired finish from the following:

For superior performance, 3 coat PVDF system including a thermal setting application of 70% fluoropolymer resin. OR High performance 2 coat, PVDF system including a thermal setting application of 70% fluoropolymer resin. OR Pigmented Organic Thermal Setting Finish 1 coat system meeting or exceeding AAMA 2603. OR (Color Anodize) Ensure aluminum finish is colour anodized in accordance with Aluminum Association Finish Designation AA-M12C22A44, Class I, minimum 0.018 mm (0.7 mils) thick finish. Color to be selected by consultant. OR (Clear Anodize) Ensure aluminum finish is clear anodized in accordance with Aluminum Association Finish Designation AA-M12C22A41, Class I, minimum 0.018 mm (0.7 mils) thick for exterior applications and AA-12C22A31, Class II, minimum 0.01 mm (0.4 mils) thick for interior applications.

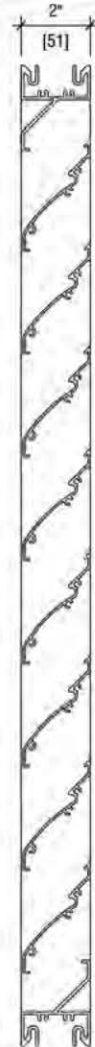

VERTICAL SECTION

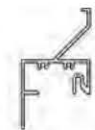

FLANGE FRAME
OPTIONAL



GLAZING FRAME
OPTIONAL

PERFORMANCE RATINGS – LOUVER MODEL H2451

FREE AREA CHART

		Louver Width				
		12	24	36	48	60
inches	mm	305	610	914	1219	1524
Free Area - Square Feet / Square Meters						
Louver Height	12	0.26	0.56	0.86	1.15	1.45
	305	0.02	0.05	0.08	0.11	0.13
	24	0.69	1.46	2.23	3.00	3.77
	610	0.06	0.14	0.21	0.28	0.35
	36	1.15	2.44	3.72	5.00	6.29
	914	0.11	0.23	0.35	0.47	0.58
	48	1.56	3.30	5.04	6.78	8.53
	1219	0.14	0.31	0.47	0.63	0.79
	60	2.01	4.24	6.48	8.72	10.96
	1524	0.19	0.39	0.60	0.81	1.02
	72	2.43	5.15	7.87	10.59	13.31
	1829	0.23	0.48	0.73	0.98	1.24
	84	2.86	6.06	9.26	12.46	15.65
	2134	0.27	0.56	0.86	1.16	1.45
	96	3.31	7.01	10.70	14.40	18.09
	2438	0.31	0.65	0.99	1.34	1.68
	108	3.74	7.91	12.08	16.25	20.43
	2743	0.35	0.74	1.12	1.51	1.90
120	4.16	8.81	13.46	18.11	22.76	
3048	0.39	0.82	1.25	1.68	2.12	
132	4.49	9.50	14.51	19.52	24.53	
3353	0.42	0.88	1.35	1.81	2.28	
144	5.14	10.88	16.62	22.35	28.09	
3658	0.48	1.01	1.54	2.08	2.61	

MODEL H4451 STORM BLADE LOUVERED PENTHOUSE

PERFORMANCE

Performance Rating Standard	AMCA Standard 500L
Louver Type	Mullion or Continuous Line Construction
Louver Depth	4" (102 mm)
Blade Angle	45°
Free Area – 4'x4' Unit	8.12 sq.ft. (0.755 m ²)
Percentage Free Area	51%
Free Area Velocity at Beginning Point of Water Penetration (0.01 oz / ft ²)	658 FPM (3.34 m/s)
Air Volume at Beginning Point of Water Penetration 4' x 4' Unit (test duration of 15 minutes)	5343 CFM (2.52 m ³ /s)
Pressure Drop at Beginning Point of Water Penetration	.077 in. H ₂ O (19.18 Pa)
Notes	Tested without bird screens

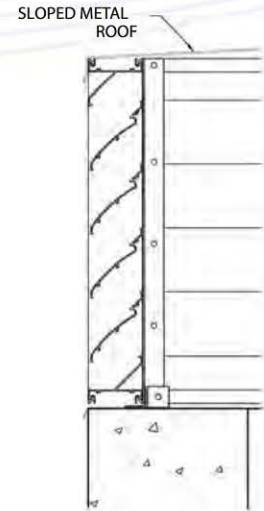

Model H4451 shown.
Also available with other blade profiles.
Call us for assistance.

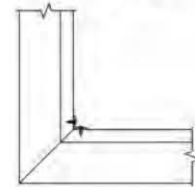

MITERED CORNER PLAN

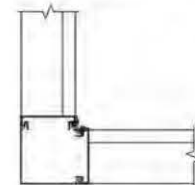

BOXED CORNER PLAN

ABBREVIATED SPECIFICATION

Where indicated on drawings, supply and install 4" (102 mm) deep storm blade, louvered penthouse Model P4451. Submit all details to consultant for approval prior to fabrication. Head, sill, jambs and mullions shall have a minimum thickness of 0.080" (2.0 mm) 6063-T5 aluminum alloy.

Blades shall be continuous, 0.080" (2.0 mm) 6063-T5 aluminum alloy with a storm hook design. Louvers shall be supplied with a 1/2" (12 mm), 19 gauge (1 mm) welded and regalvanized wire mesh in a mill finish, aluminum frame. Fasteners shall be standard zinc plated steel or stainless steel.

Materials Manufacturer: Ten Plus Architectural Products Ltd., 26 - 6535 Millcreek Drive, Mississauga, Ontario, Canada, L5N 2M2; Phone: (866) 884-0717; Email: info@tenplus-online.com; URL: www.tenplus-online.com

Structural supports shall be designed and furnished by the louver manufacturer to support a wind load of 20 psf (958Pa), unless specified otherwise. Any louver opening greater than 10' (3 m) high, will require a horizontal girt, at mid span by others.

The louver manufacturer shall submit data, on a 4' x 4' (1.2 x 1.2 m) unit, showing that the louver performs to the following criteria, based on tests & procedures performed in accordance with the AMCA Publication 511, and comply with the "Certified Ratings Program" licensed to bear the AMCA seal:

- Free area = 8.12 sq. ft. (0.755 m²)
- Free area velocity at point of beginning water penetration = 658 FPM (3.34 m/s)
- Intake pressure drop at beginning point of water penetration = 0.077 in. H₂O (19.18 Pa)

Louvers shall be fabricated with mill finish aluminum and the finish shall be applied after assembly. Select desired finish from the following:

For superior performance, 3 coat PVDF system including a thermal setting application of 70% fluoropolymer resin. OR High performance 2 coat, PVDF system including a thermal setting application of 70% fluoropolymer resin. OR Pigmented Organic Thermal Setting Finish 1 coat system meeting or exceeding AAMA 2603. OR (Color Anodize) Ensure aluminum finish is colour anodized in accordance with Aluminum Association Finish Designation AA-M12C22A44, Class I, minimum 0.018 mm (0.7 mils) thick finish. Color to be selected by consultant. OR (Clear Anodize) Ensure aluminum finish is clear anodized in accordance with Aluminum Association Finish Designation AA-M12C22A41, Class I, minimum 0.018 mm (0.7 mils) thick for exterior applications and AA-12C22A31, Class II, minimum 0.01 mm (0.4 mils) thick for interior applications.



Ten Plus Architectural Products Ltd. certifies that louver model H4451 shown herein is licensed to bear the AMCA seal. The ratings shown are based on tests and procedures performed in accordance with AMCA Publication 511 and comply with the requirements of the AMCA Certified Ratings Program. The AMCA Certified Ratings Seal applies only to Air Performance, Water Penetration ratings.

Submittal H4451 January 12, 2013
© Copyright 2013 Ten Plus Architectural Products Ltd.

Ten Plus Architectural Products Ltd. reserves the right to make design changes or to withdraw product without notice.

ACOUSTICAL LOUVERS

ABBREVIATED SPECIFICATION

Where indicated on drawings, supply and install Model A6457, 6" (152 mm) deep, acoustical louver. Submit all details to consultant for approval prior to fabrication. Blades, head, sill, jambs and mullions shall have a nominal thickness of 0.080" (1.57 mm) formed aluminum sheet. All blades, head and sill cavities shall be packed with acoustical insulation.

OR

Where indicated on drawings, supply and install Model A8457, 8" (203 mm) deep, acoustical louver. Submit all details to consultant for approval prior to fabrication. Blades, head, sill, jambs and mullions shall have a nominal thickness of 0.080" (1.57 mm) formed aluminum sheet. All blades, head and sill cavities shall be packed with acoustical insulation.

OR

Where indicated on drawings, supply and install Model AF1245, 12" (305 mm) deep, acoustical louver as manufactured by Ten Plus Architectural Products Ltd. Submit all details to consultant for approval prior to fabrication. Blades, head, sill, jambs and mullions shall have a nominal thickness of 0.080" (1.57 mm) formed aluminum sheet. All blades, head and sill cavities shall be packed with acoustical insulation.

Louvers shall be supplied with a 1/2" (12 mm), 19 gauge (1 mm) welded and regalvanized wire mesh in a mill finish, aluminum frame. Fasteners shall be standard zinc plated steel or stainless steel.

Materials Manufacturer: Ten Plus Architectural Products Ltd., 26 - 6535 Millcreek Drive, Mississauga, Ontario, Canada, L5N 2M2; Phone: (866) 884-0717; Email: info@tenplus-online.com; URL: www.tenplus-online.com

Structural supports shall be designed and furnished by the Louver manufacturer to support a wind load of 20 psf (958 Pa), unless specified otherwise. Any Louver opening greater than 10' (3 m) high, will require a horizontal girt, at mid span by others.

Louvers shall be fabricated with mill finish aluminum and the finish shall be applied after assembly. Select desired finish from the following:

For superior performance, 3 coat PVDF system including a thermal setting application of 70% fluoropolymer resin. OR High performance 2 coat, PVDF system including a thermal setting application of 70% fluoropolymer resin. OR Pigmented Organic Thermal Setting Finish 1 coat system meeting or exceeding AAMA 2603. OR (Color Anodize) Ensure aluminum finish is colour anodized in accordance with Aluminum Association Finish Designation AA-M12C22A44, Class I, minimum 0.018 mm (0.7 mils) thick finish. Color to be selected by consultant. OR (Clear Anodize) Ensure aluminum finish is clear anodized in accordance with Aluminum Association Finish Designation AA-M12C22A41, Class I, minimum 0.018 mm (0.7 mils) thick for exterior applications and AA-12C22A31, Class II, minimum 0.01 mm (0.4 mils) thick for interior applications.

TRANSMISSION LOSS (dB)

MODEL	DEPTH	Octave Band	1	2	3	4	5	6	7	8
		Frequency	63	125	250	500	1000	2000	4000	8000
A6457	152mm / 6"		7	7	7	8	11	15	14	14
A8457	203mm / 8"		7	7	8	10	17	18	16	16
A12457	305mm / 12"		7	7	11	14	19	19	17	17

FREE FIELD NOISE REDUCTION (dB)

MODEL	DEPTH	Octave Band	1	2	3	4	5	6	7	8
		Frequency	63	125	250	500	1000	2000	4000	8000
A6457	152mm / 6"		13	13	13	14	17	21	20	20
A8457	203mm / 8"		13	13	14	16	23	24	22	22
A12457	305mm / 12"		13	13	17	20	25	25	23	23

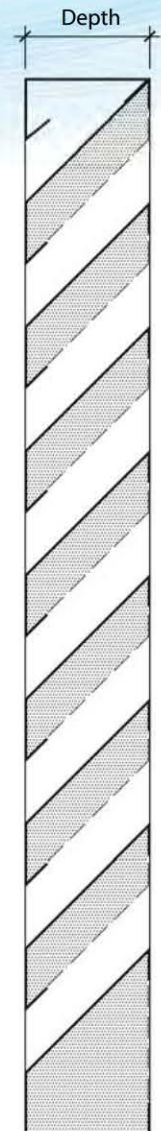

CHANNEL FRAME STANDARD

FLANGE FRAME OPTIONAL

GLAZING FRAME OPTIONAL

MODEL S4522 LOUVERED VISION SCREEN

DESCRIPTION

Louver Type	Mullion or Continuous Line Construction
Louver Depth	4" (102 mm)
Blade Angle	52°

ABBREVIATED SPECIFICATION

Where indicated on drawings, supply and install 4" (102 mm) deep louvered vision screen Model S4522. Submit all details to consultant for approval prior to fabrication. Head, sill, jambs and mullions shall have a nominal thickness of 0.080" (2. mm) 6063-T5 aluminum alloy.

Inverted blades shall be continuous, 0.080" (2 mm) thick 6063-T5 aluminum alloy. Fasteners shall be standard zinc plated steel or stainless steel.

Materials Manufacturer: Ten Plus Architectural Products Ltd., 26 - 6535 Millcreek Drive, Mississauga, Ontario, Canada, L5N 2M2; Phone: (866) 884-0717; Email: info@tenplus-online.com; URL: www.tenplus-online.com

HSS framing structure to be provided by the Structural Steel trade; vertical louver supports shall be designed and furnished by the louvered screen manufacturer to support a wind load of 20 psf (958 Pa), unless specified otherwise. Any louvered roof screen greater than 10' (3 m) high, will require a horizontal girt, at mid span by others.

Louvered screens shall be fabricated with mill finish aluminum and the finish shall be applied after assembly. Select desired finish from the following:

For superior performance, 3 coat PVDF system including a thermal setting application of 70% fluoropolymer resin. OR High performance 2 coat, PVDF system including a thermal setting application of 70% fluoropolymer resin. OR Pigmented Organic Thermal Setting Finish 1 coat system meeting or exceeding AAMA 2603. OR (Color Anodize) Ensure aluminum finish is colour anodized in accordance with Aluminum Association Finish Designation AA-M12C22A44, Class I, minimum 0.018 mm (0.7 mils) thick finish. Color to be selected by consultant. OR (Clear Anodize) Ensure aluminum finish is clear anodized in accordance with Aluminum Association Finish Designation AA-M12C22A41, Class I, minimum 0.018 mm (0.7 mils) thick for exterior applications and AA-12C22A31, Class II, minimum 0.01 mm (0.4 mils) thick for interior applications.

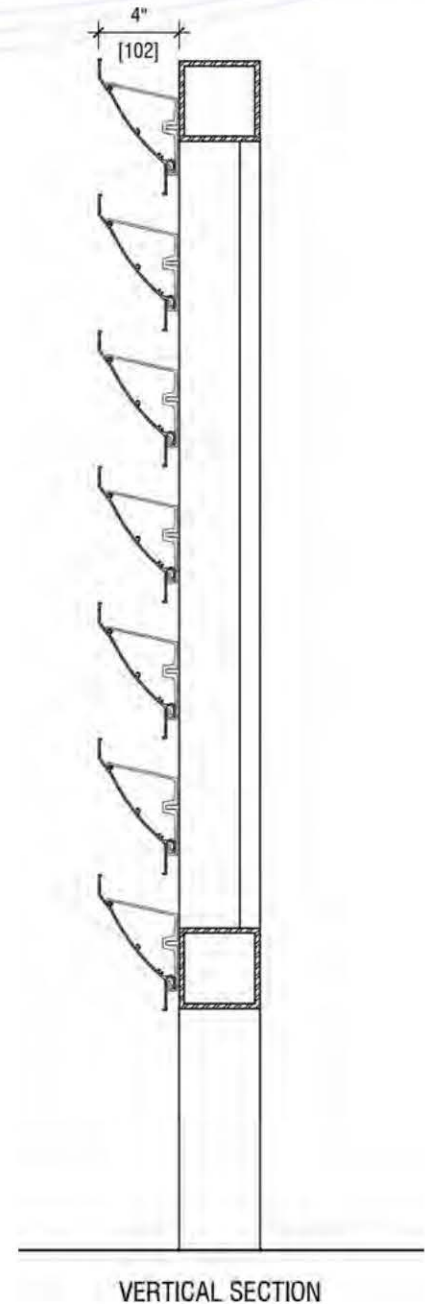

MODEL V4454 LOUVERED VISION SCREEN

PERFORMANCE

Louver Type	Mullion or Continuous Line Construction
Louver Depth	4" (102 mm)
Blade Angle	45°

ABBREVIATED SPECIFICATION

Where indicated on drawings, supply and install 4" (102 mm) deep sight proof, louvered vision screen Model S4454. Submit all details to consultant for approval prior to fabrication. Head, sill, jambs and mullions shall have a minimum thickness of 0.080" (2. mm) 6063-T5 aluminum alloy.

Blades shall be continuous, 0.080" (2 mm) 6063-T5 aluminum alloy. Louvers shall be supplied with a 1/2" (12 mm), 19 gauge (1 mm) welded and regalvanized wire mesh in a mill finish, aluminum frame. Fasteners shall be standard zinc plated steel or stainless steel.

Materials Manufacturer: Ten Plus Architectural Products Ltd., 26 - 6535 Millcreek Drive, Mississauga, Ontario, Canada, L5N 2M2; Phone: (866) 884-0717; Email: info@tenplus-online.com; URL: www.tenplus-online.com

Structural supports shall be designed and furnished by the louver manufacturer to support a wind load of 20 psf (958 Pa), unless specified otherwise. Any louver opening greater than 10' (3 m) high, will require a horizontal girt, at mid span by others.

Louvers shall be fabricated with mill finish aluminum and the finish shall be applied after assembly. Select desired finish from the following:

For superior performance, 3 coat PVDF system including a thermal setting application of 70% fluoropolymer resin. OR High performance 2 coat, PVDF system including a thermal setting application of 70% fluoropolymer resin. OR Pigmented Organic Thermal Setting Finish 1 coat system meeting or exceeding AAMA 2603. OR (Color Anodize) Ensure aluminum finish is colour anodized in accordance with Aluminum Association Finish Designation AA-M12C22A44, Class I, minimum 0.018 mm (0.7 mils) thick finish. Color to be selected by consultant. OR (Clear Anodize) Ensure aluminum finish is clear anodized in accordance with Aluminum Association Finish Designation AA-M12C22A41, Class I, minimum 0.018 mm (0.7 mils) thick for exterior applications and AA-12C22A31, Class II, minimum 0.01 mm (0.4 mils) thick for interior applications.

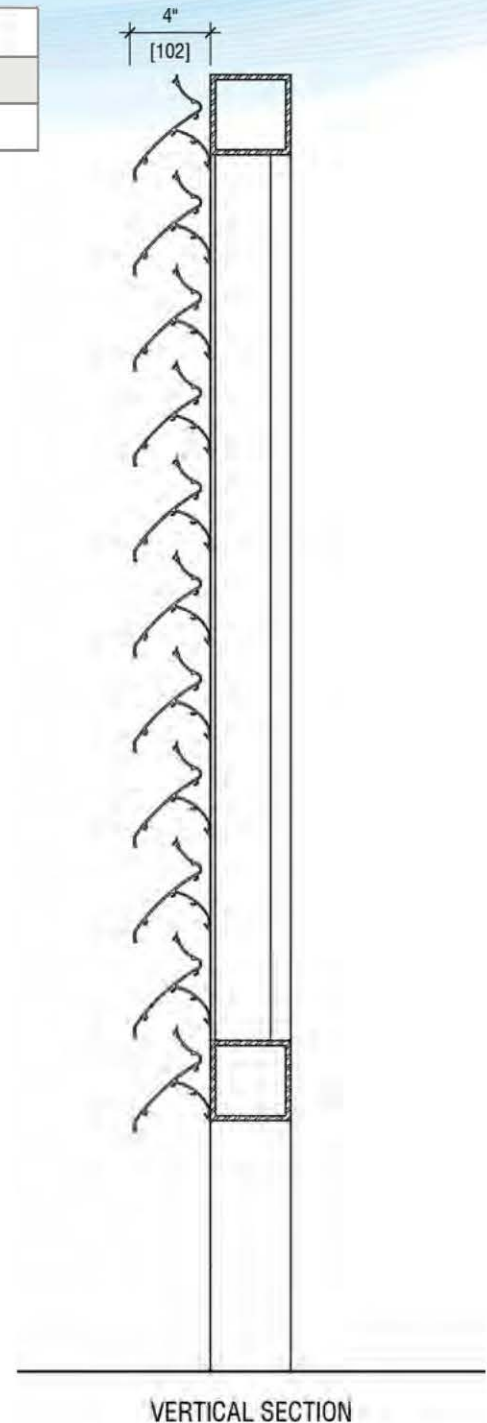

T1300 THINLINE LOUVER

The T1300, by TEN Plus Architectural, is a high free area, extruded aluminum thinline louver. This model is ideal for small openings, PTAC applications or for decorative and interior applications.

ABBREVIATED SPECIFICATION

Where indicated on drawings, supply and install 1 1/4" (32 mm) deep Model T1300 thin line louver. Blades, head, sill and jambs shall have a minimum thickness of 0.063" (1.6mm) 6063-T5 aluminum alloy. Louver shall be supplied with standard 16 x 18 aluminum mesh insect screen.

Materials Manufacturer: Ten Plus Architectural Products Ltd., 26 - 6535 Millcreek Drive, Mississauga, Ontario, Canada, L5N 2M2; Phone: (866) 884-0717; Email: info@tenplus-online.com; URL: www.tenplus-online.com

Louver shall be fabricated with mill finish aluminum and the finish shall be applied after assembly. Select desired finish from the following:

For superior performance, 3 coat PVDF system including a thermal setting application of 70% fluoropolymer resin. OR High performance 2 coat, PVDF system including a thermal setting application of 70% fluoropolymer resin. OR Pigmented Organic Thermal Setting Finish 1 coat system meeting or exceeding AAMA 2603. OR (Color Anodize) Ensure aluminum finish is color anodized in accordance with Aluminum Association Finish Designation AA-M12C22A44, Class I, minimum 0.018 mm (0.7 mils) thick finish. Color to be selected by consultant. OR (Clear Anodize) Ensure aluminum finish is clear anodized in accordance with Aluminum Association Finish Designation AA-M12C22A41, Class I, minimum 0.018 mm (0.7 mils) thick for exterior applications and AA-12C22A31, Class II, minimum 0.01 mm (0.4 mils) thick for interior applications.

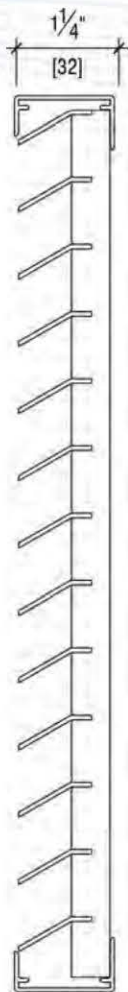

Glazing Frame
Optional

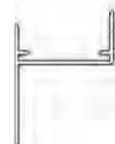

Flange Frame
Optional

G1384 DOOR LOUVER

The G1384, by TEN Plus Architectural, incorporates inverted "Y" blades to maximize free area while retaining the privacy and security of a sight proof and tamper proof design. This profile provides exceptional strength and protection against vandalism.

ABBREVIATED SPECIFICATION

Where indicated on drawings, supply and install 1 3/8" (35 mm) deep Model D1384 door louver. Blades, head, sill and jambs shall have a minimum thickness of 0.063" (1.6mm) 6063-T5 aluminum alloy.

Materials Manufacturer: Ten Plus Architectural Products Ltd., 26 - 6535 Millcreek Drive, Mississauga, Ontario, Canada, L5N 2M2; Phone: (866) 884-0717; Email: info@tenplus-online.com; URL: www.tenplus-online.com

Louver shall be fabricated with clear anodized aluminum finish.

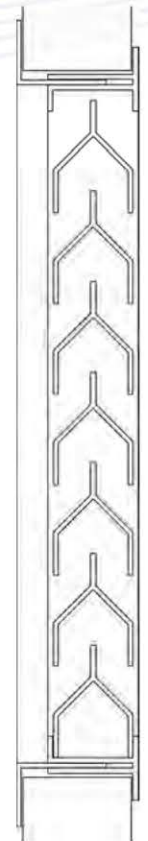

B4450 BRICK VENT

The B4450, by TEN Plus Architectural, is a heavy-duty extruded aluminum block vent. The aluminum construction makes it resistant to the corrosive environment of foundation walls and chimneys. The block vent comes with an insect screen and features both extended head and sill to provide a drip edge for water to travel around the opening. The sill has an integral water stop at the back to prevent any water flowing into the building.

ABBREVIATED SPECIFICATION

Where indicated on drawings, supply and install 4" (102 mm) deep Model B4450 heavy duty, extruded aluminum block vents with extended head and sill and integral water stop. Blades, head, sill and jambs shall have a minimum thickness of 0.109" (2.54mm) 6063-T5 aluminum alloy. Block vents shall be supplied with standard 16 x 18 aluminum mesh insect screen.

Materials Manufacturer: Ten Plus Architectural Products Ltd., 26 - 6535 Millcreek Drive, Mississauga, Ontario, Canada, L5N 2M2; Phone: (866) 884-0717; Email: info@tenplus-online.com; URL: www.tenplus-online.com

Block vents shall be fabricated with mill finish aluminum and the finish shall be applied after assembly. Select desired finish from the following:

For superior performance, 3 coat PVDF system including a thermal setting application of 70% fluoropolymer resin. OR High performance 2 coat, PVDF system including a thermal setting application of 70% fluoropolymer resin. OR Pigmented Organic Thermal Setting Finish 1 coat system meeting or exceeding AAMA 2603. OR (Color Anodize) Ensure aluminum finish is colour anodized in accordance with Aluminum Association Finish Designation AA-M12C22A44, Class I, minimum 0.018 mm (0.7 mils) thick finish. Color to be selected by consultant. OR (Clear Anodize) Ensure aluminum finish is clear anodized in accordance with Aluminum Association Finish Designation AA-M12C22A41, Class I, minimum 0.018 mm (0.7 mils) thick for exterior applications and AA-12C22A31, Class II, minimum 0.01 mm (0.4 mils) thick for interior applications.

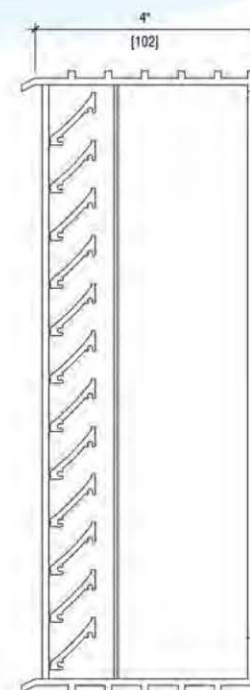

VERTICAL SECTION



SOLAR CONTROL

Ten Plus Sunshades combine form and function to enhance building esthetics, maximize economic performance and reduce the adverse impact on the environment. By reducing direct sunlight and glare, Ten Plus sunshades increase the quality of occupant comfort while reducing the load on the building's cooling system.

From standard shapes to custom profiles consultants are granted the flexibility to change outrigger type; blade type; fascia type and method of suspension. If you don't see it, we will fabricate it according to your design. Call our office for more information and assistance.

ABBREVIATED SPECIFICATION

Where indicated on drawings, supply and install fixed sunshades, consisting of blades, outriggers, fascia and anchoring brackets, required to provide sun and glare-control around glazing areas.

Submit shop drawings showing construction and anchorage of exterior sunshades including, details of all elements of assembly and construction. Shop drawings shall bear the seal and signature of a Professional Engineer registered in the place of the Work and experienced in the design and fabrication methods used.

Materials Manufacturer: Ten Plus Architectural Products Ltd., 26 - 6535 Millcreek Drive, Mississauga, Ontario, Canada, L5N 2M2; Phone: (866) 884-0717; Email: info@tenplus-online.com; URL: www.tenplus-online.com

Design sunshades including anchorage to accommodate, without failure, exterior stresses expected in the geographical area for this project, in accordance with the latest edition of the National Building Code - 30 year probability climatic data.

Aluminum: AA6063-T5 alloy, anodizing quality. Brackets and Reinforcements: Manufacturer's standard high strength aluminum with non-staining, nonferrous shims for aligning system components.

Fasteners, Sealants and Gaskets: Manufacturer's standard corrosion resistant, non-staining, non-bleeding fasteners and accessories compatible with adjacent materials.

















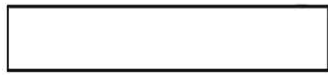

Fixed Sunshade Components:

Provide sunshades compatible with wall cladding system, structural supports, and the following components: (select from the components chart in the following order):

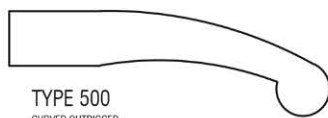
Blade type; Outrigger type; Fascia type

Sunshades shall be fabricated with mill finish aluminum and the finish shall be applied after assembly. Select desired finish from the following:

For superior performance, 3 coat PVDF system including a thermal setting application of 70% fluoropolymer resin. OR High performance 2 coat, PVDF system including a thermal setting application of 70% fluoropolymer resin. OR Pigmented Organic Thermal Setting Finish 1 coat system meeting or exceeding AAMA 2603. OR (Color Anodize) Ensure aluminum finish is colour anodized in accordance with Aluminum Association Finish Designation AA-M12C22A44, Class I, minimum 0.018 mm (0.7 mils) thick finish. Color to be selected by consultant. OR (Clear Anodize) Ensure aluminum finish is clear anodized in accordance with Aluminum Association Finish Designation AA-M12C22A41, Class I, minimum 0.018 mm (0.7 mils) thick for exterior applications and AA-12C22A31, Class II, minimum 0.01 mm (0.4 mils) thick for interior applications.

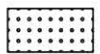
SUNSHADE COMPONENTS		
BLADES	OUTRIGGERS	FASCIA
 TYPE L6 LOUVER BLADE	 TYPE 100 ROUNDED FACE OUTRIGGER	 TYPE 10 NO FASCIA
 TYPE A4 4" [100mm] AIRFOIL BLADE	 TYPE 200 STRAIGHT FACE OUTRIGGER	 TYPE 20 CUSTOM FORMED FASCIA
 TYPE A6 6" [150mm] AIRFOIL BLADE	 TYPE 300 CHANNEL OUTRIGGER	 TYPE 30 ROUND FASCIA
 TYPE A8 LOUVER BLADE	 TYPE 400 TAPERED OUTRIGGER	 TYPE 40 RECTANGULAR FASCIA
 TYPE C2 ROUND BLADE	 TYPE 500 CURVED OUTRIGGER	 TYPE 50 BULL NOSE FASCIA
 TYPE R4 4" [100mm] RECTANGULAR BLADE	 TYPE 600 BLUNT FACE OUTRIGGER	
 TYPE R6 6" [150mm] RECTANGULAR BLADE	 TYPE 700 CUSTOM CUT OUTRIGGER	
 TYPE P1 PERFORATED BLADE / SHADE		

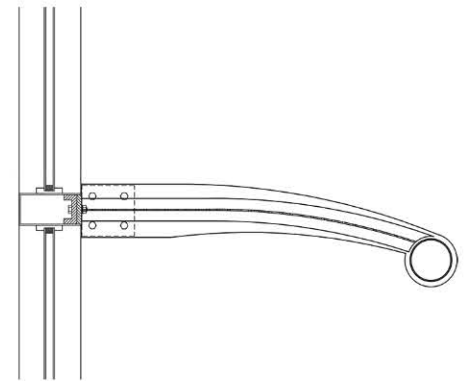

MODEL P1-500-30

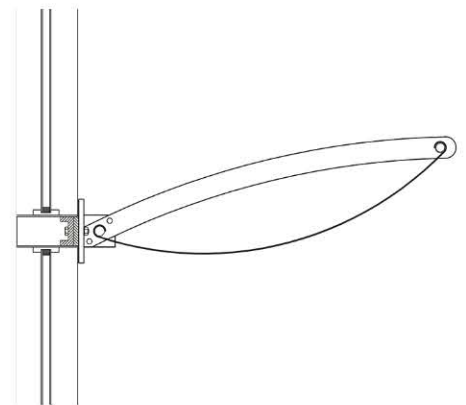

MODEL P1-700-10

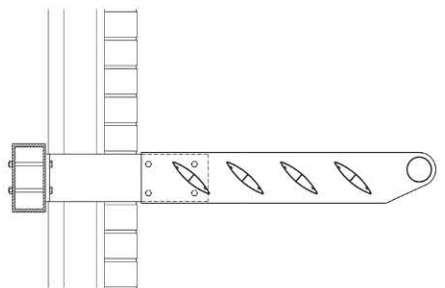

MODEL A6-600-30

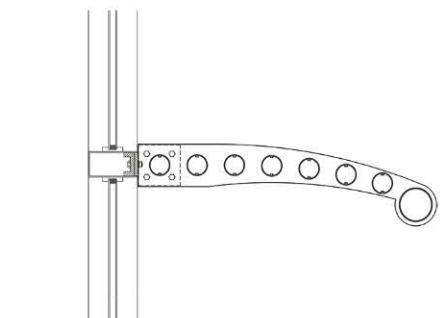

MODEL C2-500-30

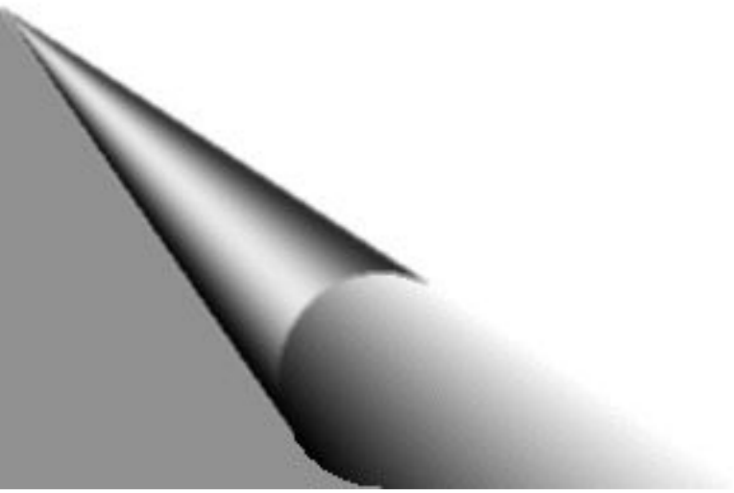



ARCHITECTURAL PRODUCTS LTD.

tel 905-363-2306 • fax 905-363-2309 • toll-free 866-884-0717
email: info@tenplus-online.com

26 - 6535 Millcreek Drive
Mississauga, Ontario
Canada L5N 2M2
www.tenplus-online.com

We also Offer

Footgrilles
Expansion Joint Covers
Projection Screens
Custom Stainless Steel Grating
Custom Metal Fabrications